

Mustang Double Adjustable Steel Coil-over Struts & Aluminum Adjustable Shocks

Installation to be performed by a qualified technician.

RaceStrange

- Externally accessible adjusters for compression and extension dampening
- Accurately adjust compression and extension dampening (double adjustable)
- Each strut is inspected and tested on dynamometer
- Custom valving available upon request
- Ideal for drag racing applications
- Light-weight design with durable steel body
- Robust 22mm rod and 1.375" piston diameter
- Integrated coil-over body allows for fully adjustable ride height
- Spring seat thrust bearings allow for minimal effort to adjust ride height
- Strange caster camber kit is required

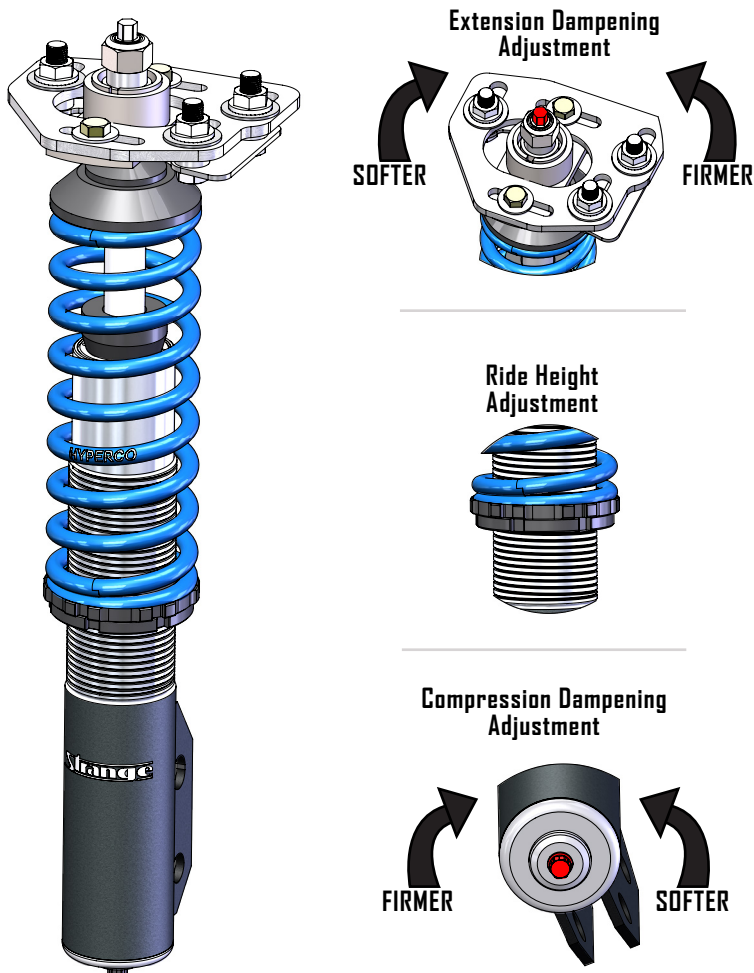

STRUTS		
Part #	Adjustability	Year
S2041	Double	1987-2004
S2043	Double	2005 -2014

Notes: 87-93 V8 models only
S2043 does not clear GT500 Shelby Wheels

SHOCKS		
Part #	Adjustability	Year
S5045	Double	64-73
S5046	Double	64-73
S5044	Double	79-93
S5050	Double	94-2004
S5042	Double	2005 - 2014
S5242	Single	2005 - 2014

Note: S5045 is the front shock
94-04 shocks do not fit Cobra with independent rear
2005-2014 shocks do not fit 2013 & 2014 GT500 with track package

REAR COILOVER SHOCKS		
Part #	Adjustability	Year
S5048	Double	79-04
S5248	Single	79-04

Note: Coil-over shock instructions see pg. 9

CASTER CAMBER KITS	
Part #	Year
S6002CC79	79-89
S6002CC90	90-93
S6002CC94	94-2004
S6002CC05	2005 - 2014

ADDITIONAL PARTS	
Part #	Description
S1413	Spanner Wrench

Hypercoil & Knight springs are available in a variety of rates and lengths

1987-2011 Ford Mustang Strut packages are available with springs and caster camber kits.
Call for information

Mustang Double Adjustable Steel Coil-over Struts & Aluminum Adjustable Shocks

Strange Caster Camber Kits

- Teflon lined bearing
- Tig welded construction
- Stainless steel bushings/spacers
- Durable & clean zinc plating finish
- Steel plates

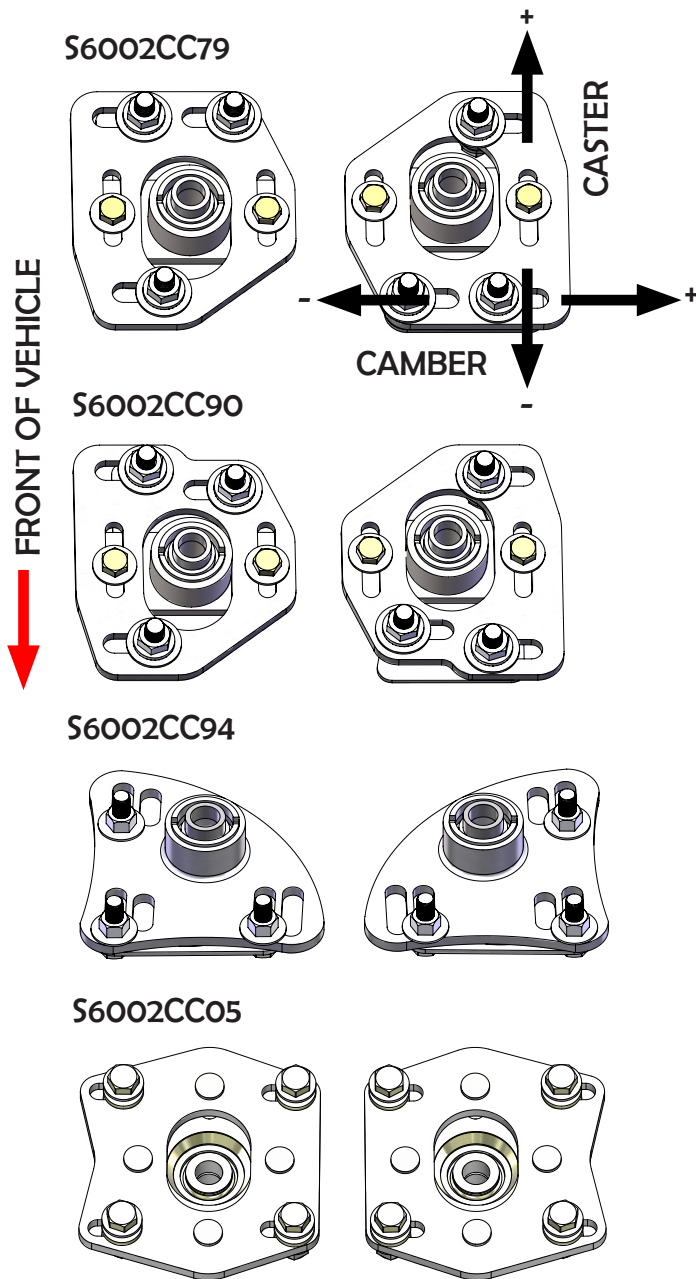

Stroke Lengths

- A Compressed Length
- B Extended Length

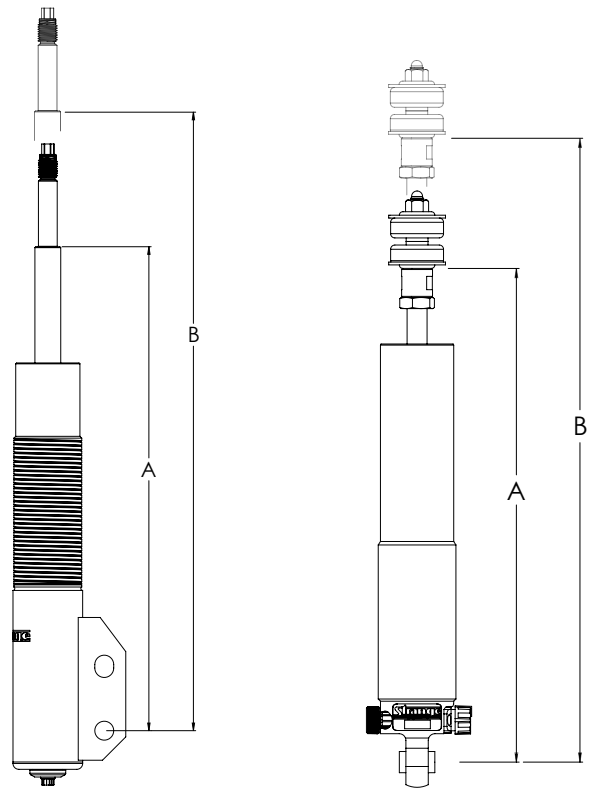

STRUTS		
Year	A	B
87-2004	13.1"	19.1"
05 +	12.9"	20.1"

SHOCKS		
Year	A	B
64-73 (front)	8.50	12.9
64-73	11.7	17.2
79-93	12.9"	20.1"
94-2004	14.3"	19.7"
05 +	12.9"	20.1"

Lengths listed are for Strange struts/shocks

94+ applications will have 1" shorter extended and compressed lengths allowing for a lower ride height while maintaining OEM stroke length. 87-93 maintain OEM extended and compressed lengths.

⚠ The teflon lined bearings do NOT need to be lubricated

Mustang Double Adjustable Steel Coil-over Struts & Aluminum Adjustable Shocks

NOTES

The front suspension of a drag race vehicle is tuned accordingly to rear tire reaction. When at the track, the sidewall of the rear tire and clearance between tire and fender should be observed. A rapid weight transfer that generally causes the vehicle rear to “bounce” will be evident by a sudden decrease in the tire and fender clearance as well as a sudden decrease in tire sidewall height. A slow weight transfer will generally cause tire spin and will be evident by the tire sidewall and fender to wheel clearance not decreasing significantly. Refer to notes on pg. 7 for further information. Understanding these basic principles will promote a better response to tune vehicle dynamics and suspension for superior car performance.

STRUT EXTENSION ADJUSTMENT

- 3/8 and 7/16 wrenches are used to adjust extension
- Hex is located at the top of the piston rod
- Full clockwise is the softest position
- Full counter-clockwise is the firmest position
- 3-7/8 total turns of adjustment

SHOCK EXTENSION ADJUSTMENT

- 10 settings
- Full clockwise is the firmest position
- Full counter-clockwise is the softest position
- Shipped at softest settings

STRUT COMPRESSION ADJUSTMENT

- Hex is located at the bottom of strut body
- Full clockwise is the firmest position
- Full counter-clockwise is the softest position
- 12 clicks
- 13 total settings

SHOCK COMPRESSION ADJUSTMENT

- Compression is adjustable only on double adjustable shocks
- 9 compression settings
- Full clockwise is the firmest position
- Full counter-clockwise is the softest position
- “Clicks” 1/8 every turn for fine adjustment

FRONT EXTENSION DAMPENING	
Application	Adjustment
Drag Race	0.5-1.0 turns
Street	1.25-1.5 turns
Road Race	2.0-2.5 turns

FRONT COMPRESSION DAMPENING	
Application	Adjustment
Drag Race	4 or 5
Street	4 or 5
Road Race	7 or 8

REAR EXTENSION DAMPENING	
Application	Knob Position
Drag Race	5
Street	4 or 5
Road Race	7 or 8

REAR COMPRESSION DAMPENING	
Application	Adjustment
Drag Race	2 or 3
Street	4 or 5
Road Race	7 or 8

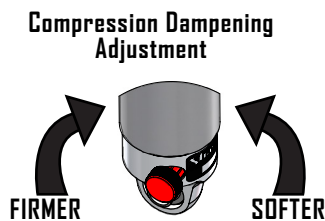
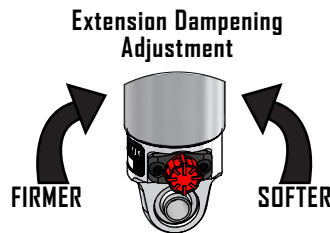

Strange Engineering struts and shocks are designed for a variety of unique vehicles and drivers. The dampening adjustments listed are starting points to begin fine tuning.

Mustang Double Adjustable Steel Coil-over Struts & Aluminum Adjustable Shocks

S2041 with
S6002CC79 & S6002CC90

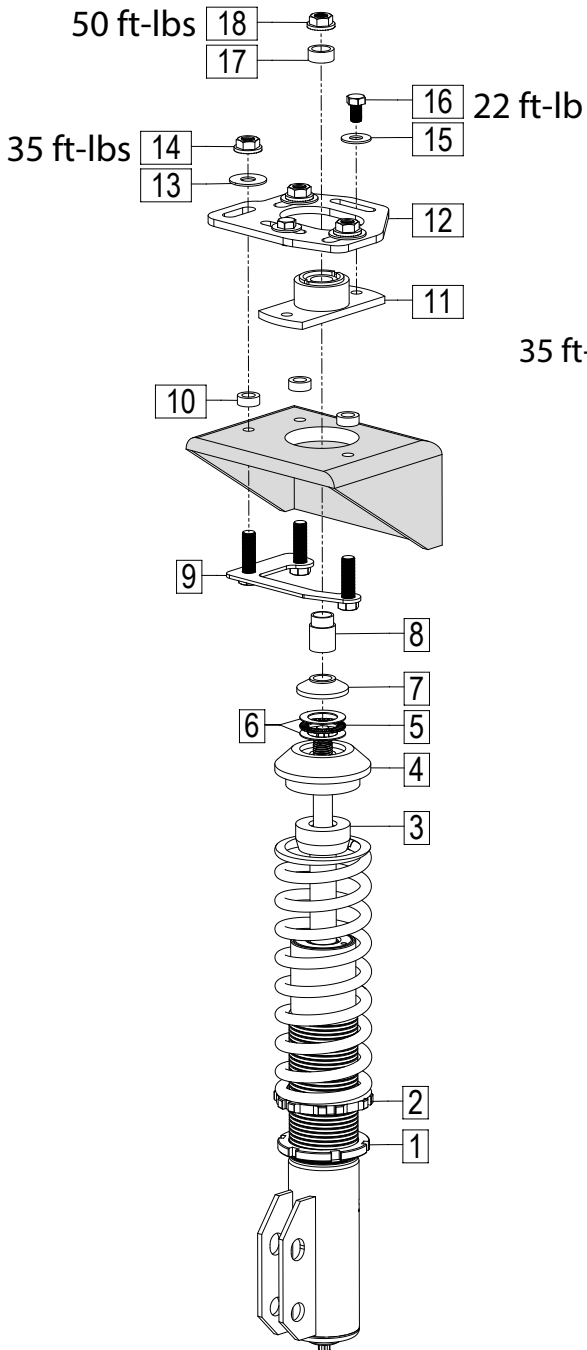

S2041 with
S6002CC94

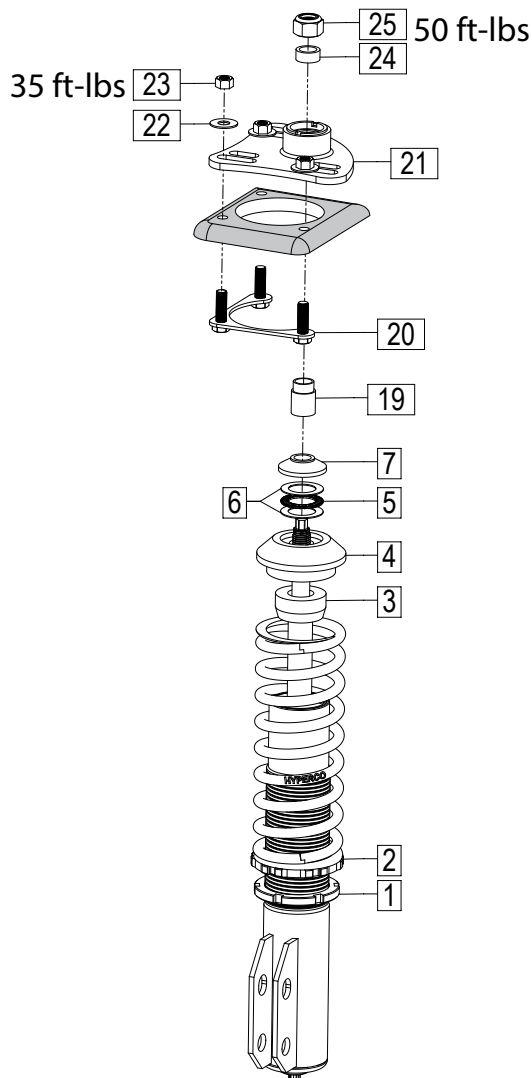

S2043 with
S6002CC05

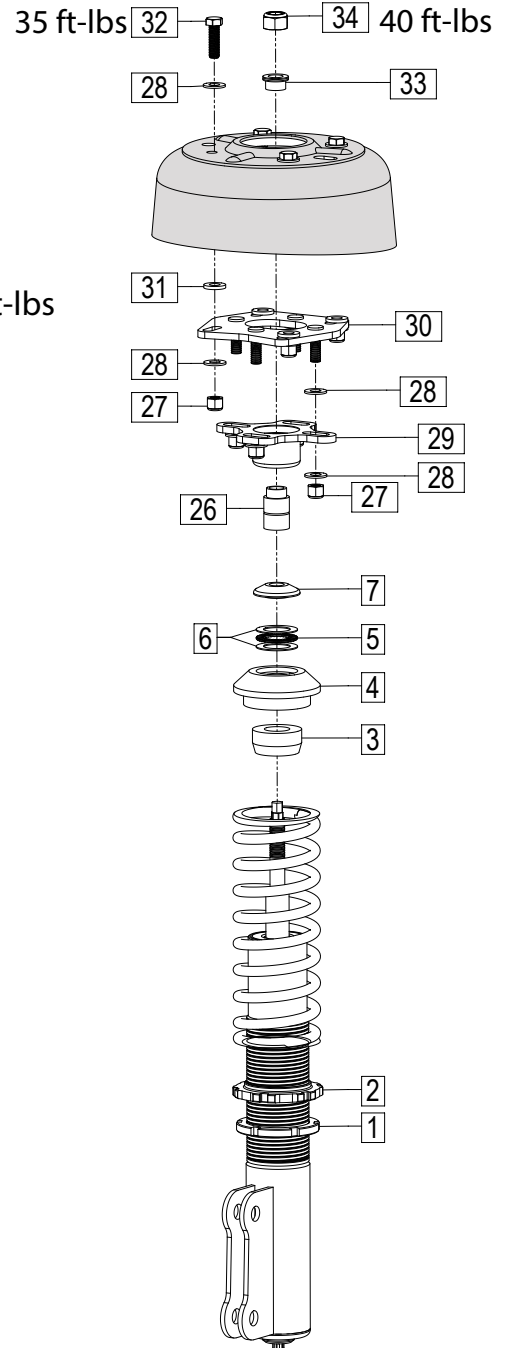

Mustang Double Adjustable Steel Coil-over Struts & Aluminum Adjustable Shocks

COMMON COMPONENTS			
ITEM#	PART#	QTY	DESCRIPTION
1	S6001C	1	Spring Seat Jam Nut
2	S6001B	1	Spring Seat Nut
3	S3600W	1	Compression Bumper
4	S6001D	1	Top Spring Seat
5	S4000N	1	Thrust Bearing
6	S4000M	2	Thrust Bearing Washer
7	S6001E	1	Thrust Bearing Cover

S6002CC79 & S6002CC90 CASTER CAMBER KIT			
ITEM#	PART#	QTY	DESCRIPTION
8	--	2	16mm ID flanged bushing
9	--	2	Stud Retainer Bracket
10	--	6	¼" Bearing Retainer Spacer
11	--	2	Bearing Retainer Bracket
12	--	2	Caster/Camber Plate S6002CC979/S6002CC90
13	--	6	7/16" Washer
14	--	6	7/16"-20 Flanged Nut
15	--	4	¾" Washer
16	--	4	¾"-24 Screw
17	--	2	¾" Thick Spacer
18	S2041H	2	M16 x 2mm Nylon Locknut

Caster/camber plate (item #12) is different for S6002CC79 & S6002CC90 kits. However, both are installed identically. Refer to pg. 2 to identify caster camber plate differences.

S6002CC94 CASTER CAMBER KIT			
ITEM#	PART#	QTY	DESCRIPTION
19	--	2	14mm ID Flanged Bushing
20	--	2	Stud Retainer Bracket
21	--	2	Caster/Camber Plate
22	--	6	¾" Washer
23	--	6	¾"-16 Serrated Flange Hex Locknut
24	--	2	¾" Thick Spacer
25	S2041H	2	M16 x 2mm Nylon Locknut

S6002CC05 CASTER CAMBER KIT			
ITEM#	PART#	QTY	DESCRIPTION
26	--	2	14mm ID spacer
27	--	16	¾"-16 locknut
28	--	32	¾" ID x 1/16" thick flat washer
29	--	2	Caster plate w/ spherical bearing
30	--	2	Camber plate w/ press in studs
31	--	8	¾" ID x 1/8" thick flat washer
32	--	8	¾"-16 x 1-1/4" long HHCS
33	--	2	14mm ID flanged bushing
34	--	2	M14 x 2mm locknut (factory thread)

Mustang Double Adjustable Steel Coil-over Struts & Aluminum Adjustable Shocks

Installation:

Steps 1-6 can be completed off the vehicle and pertains to all caster camber kits

1. Raise and support front of vehicle on a level surface using suitable equipment.
2. Consult the factory service manual to remove the factory strut. .
3. Install the spring lock nut (1) followed by the spring seat nut (2) and spring.
Slide the compression bumper (3) and top spring seat (4) over the strut piston rod .
4. Slide the thrust bearing assembly (5,6) over the piston rod followed by the thrust bearing cover (7).
5. Slide the stepped bushing (8/19/26) over the piston rod. Ensure smaller diameter faces up.
6. Set the strut aside and follow the appropriate caster camber kit instructions below to install the caster camber kit on the strut tower.

Steps 7-10 pertain to S6002CC79 and S6002CC90 kit

7. Place the bearing retainer bracket (11) under the caster/camber plate (12) and secure with the 3/8" screws and washers (15,16). Do not torque the screws.
8. Position the stud retainer bracket (9) on the underside of the strut tower.
9. Slide the 1/4" spacers (10) through the studs to seat against the top of the strut tower.
10. Slide the caster/camber plate and bearing retainer bracket assembly (11,12) through the studs to seat against the spacers (10). Secure the assembly to the shock tower using the 7/16" nut and washers (14,13). Do not torque the nuts yet.

Steps 11-12 pertain to S6002CC94 Kkits

11. Install the stud retainer bracket (20) on the underside of the strut tower.
12. Slide the caster/camber plate (21) through the studs to seat against the shock tower. Secure the assembly to the shock tower using the 3/8" nut and washers (23,22). Do not torque the nuts yet.

Steps 13-15 pertain to S6002CC05 Kkits

13. Place the bearing retainer bracket (29) under the caster/camber plate (30) with washers (28) between the two surfaces and secure with the 3/8" screws and washers (27,28). Do not torque the screw.
14. Place the caster/camber plate (30,29) on the underside of the shock tower with washers (31) between the surfaces.
15. Secure the assembly with the three top bolts and washers (28,32) and nut and washers (27,28).

The following steps pertain to all kits

16. Install the strut assembly by first installing the lower factory nuts and bolts. Then raise the lower control arm with a jack while aligning the strut shaft with the bearing in the caster/camber plate. Ensure the stepped bushings (8/19/26) slide into the bearing.
17. Slide the spacer (17/24/33) over the strut piston rod and install the strut locknut (18/25/34).
18. Torque the locknuts to specified torque. Do not use an impact wrench. Damage to the strut internal components will result. Use a 7/16" wrench on the end of the piston rod to keep it from spinning.
19. A wheel alignment must then be performed to achieve the desired caster, camber, and toe in specifications. Once complete, ensure final torque specification on all hardware.

Mustang Double Adjustable Steel Coil-over Struts & Aluminum Adjustable Shocks

WHEEL ALIGNMENT NOTES

A wheel alignment is required after the installation of these components. Alignments are possible to perform at home with proper tools, setup and careful measurements. Generally, the vehicle is set to stock alignment settings and adjustments are made accordingly to driver feedback. If the alignment is performed at a professional shop and any future adjustments to either ride height, camber, caster or toe are made note that these adjustments will effect other alignment settings and therefore it is recommended to get the vehicle re-aligned. Inspect tire wear often to ensure proper alignment. It is suggested to keep records of alignment settings for reference when making future adjustments. The bottom of this page can be used to do so.

RIDE HEIGHT ADJUSTMENT

- Rotate the spring seat nut to the desired height
- Lock the spring seat in position with the jam nut

SPRING RATE & SUSPENSION NOTES

Spring rates depend drastically on the particular vehicle setup. Below are some general guidelines to follow when choosing a spring rate. Typically, 14" long springs are used with Strange Engineering struts and caster/camber kits. For drag race applications with rear wheel drive soft spring rates are used in the front suspension to encourage weight transfer. A softer spring rate can be compressed more by the constant weight of the vehicle than a stiff spring at identical length. Therefore, a soft spring will have more kinetic energy stored for weight transfer. If the weight transfer is excessive the tire sidewall may suffer drastic deformation and unload abruptly to result in tire shake. The front extension dampening adjustment can be increased to prevent this. If there is no weight transfer occurring the front extension dampening adjustment can be decreased or a softer spring rate can be used. For the vehicle to take full advantage of weight transfer a stiff rear spring will resist compression and maintain traction. However, a spring rate which is too stiff and does not compress will transfer the weight to the tire sidewall which will eventually unload and cause uncontrollable driving conditions. The end goal with all combinations of front and rear shock settings along with spring rates is to be able to plant the tires for maximum grip by increasing the footprint. However, increasing the footprint decreases the total diameter of the tire therefore, traveling a shorter distance in a single rotation. Also note that a taller and longer tire foot print is preferable compared to merely a wide foot print. Track experience and careful documentation will result in the best combinations of strut and shock adjustment and springs.

DF

Camber _____

Toe _____

Caster _____

DR

Camber _____

Toe _____

Caster _____

PF

Camber _____

Toe _____

Caster _____

PR

Camber _____

Toe _____

Caster _____

Front Spring Rate _____

Front Spring Length _____

Rear Spring Rate _____

Rear Spring Length _____

Ride Height _____

Notes: _____

Mustang Double Adjustable Steel Coil-over Struts & Aluminum Adjustable Shocks

Strut & Shock Dyno Graphs:

The following graphs show the average resistance of the shock extension and compression forces as velocity increases.

Mustang Steel Double Adjustable Coil-over Strut
Force vs. Velocity

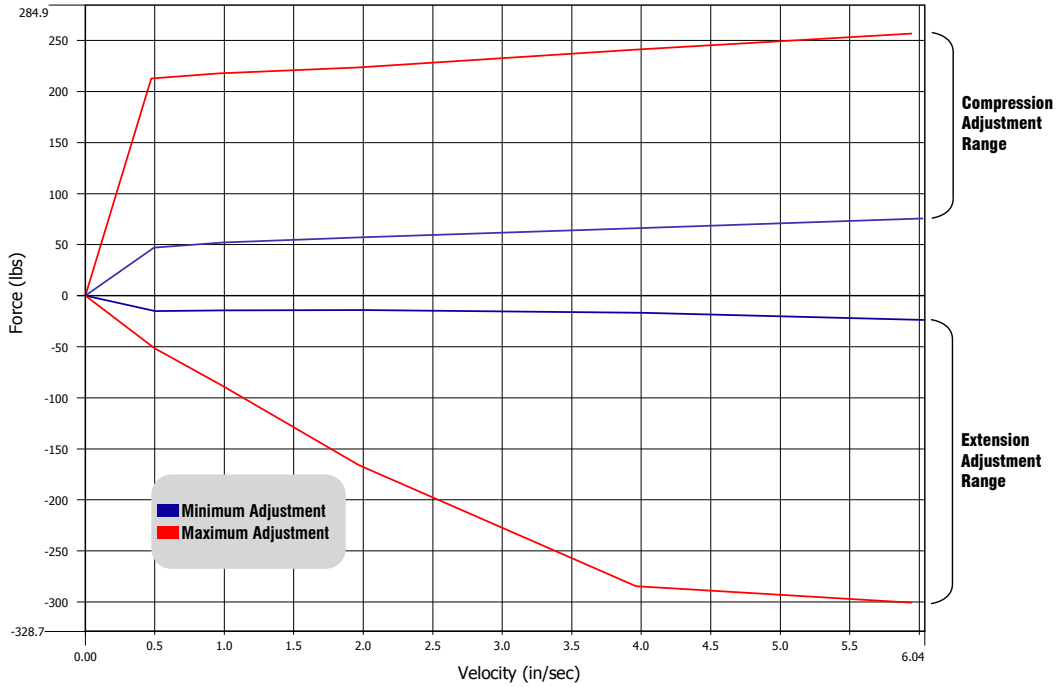

Mustang Aluminum Double Adjustable Shocks
Force vs. Velocity

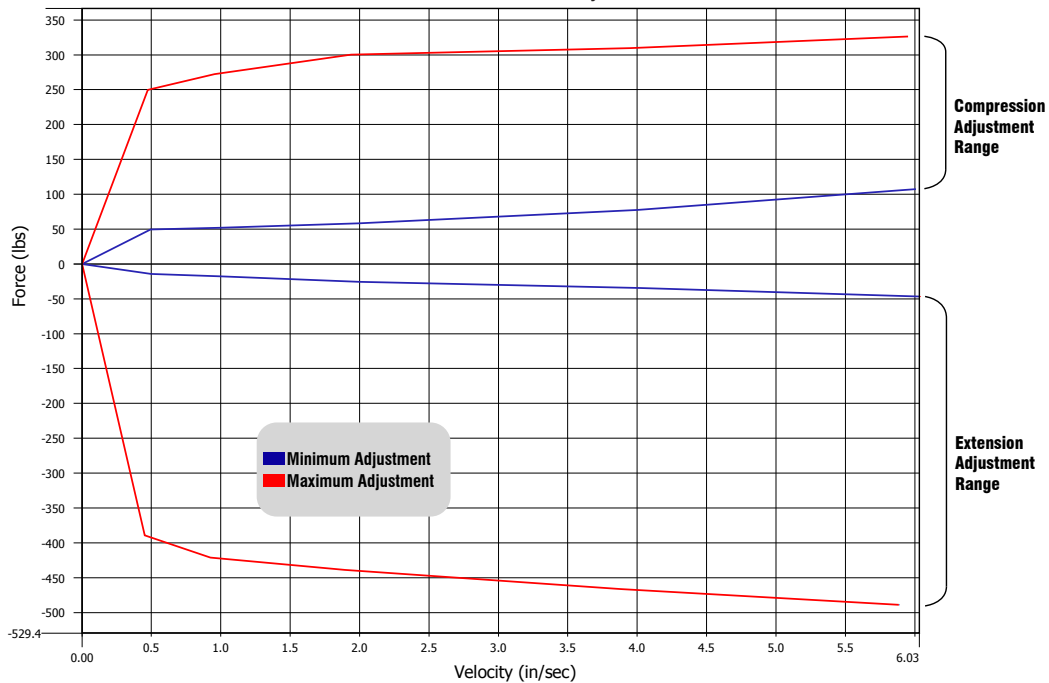

Mustang Rear Coil-over Conversion Kit 79-04

Installation: S5048 & S5248 Coilover Shocks

1. Safely raise and support the vehicle off the ground. Remove the factory shock.
2. Attach the shock mount adapter (12) to the factory shock mount location using the one of the 1/2" screws (8). Ensure the mount is perpendicular to housing.
3. Use the upper hole as a template and drill a 1/2" hole through the factory shock mount bracket on the rear end housing.
4. To install the spring onto the shock, screw the jam nut (7) and spring seat nut (6) all the way down to the bottom. Then with the top spring seat (5) removed from the shock, slide the spring over the shock. Using a suitable spring compressor, compress the spring just enough to be able to slide the top spring seat around the piston rod. Release tension on the spring compressor while aligning the spring with the top spring seat and the spring seat adapter.

Note: A 14" length spring is suggested for Stange Engineering strut and shock caster/camber kits

5. Slide a cushion washer (2) and rubber (3) on the top shock stud.
6. Slide the shock up from the bottom of the car extending the top stud mount through the hole in the body. Slide a rubber cushion (3) and cushion washer (2) over the top stud mount and then install the 3/8"-24 lock nut (1). On the underside of the car, hold the top stud mount across the machined flats using a 3/4" open end wrench. Tighten the 3/8" lock nut until the rubber cushion begins to expand slightly around the cushion washer. After installation, the carpet and interior can be reinstalled.
7. Raise the rear end housing with the jack and position the shock in the lower shock mount and secure with the 1/2" screw and nut (13, 14).

Note: For double adjustable shocks position the plastic extension knob towards the rear end housing tube.

8. Single adjustable shocks can be positioned with the extension knob facing either direction.
Torque all the hardware to the spec listed in the diagram below.

KIT CONTENTS			
ITEM#	PART#	QTY	DESCRIPTION
1	S5001Y	1	3/8"-24 Lock nut
2	S5001X	2	Cushion washer
3	S5001W	2	Shock cushion
4	S5001M	1	Spring Seat Adapter
5	S510V	1	Top Spring Seat
6	S510S	1	Spring Seat Nut
7	S510T	1	Spring Seat Jam Nut
8	B4160B	2	1/2"-20 x 1-1/2" HHCS
9	S5001KB	4	1/2" washer
10	A1026AM	1	1/2"-20 x 2-1/4" HHCS
11	H1135C	1	1/2"-20 Flexlock nut
12	H1114C	1	Lower shock mount
13	S5001KB	4	1/2" washer
14	S5001KA	2	1/2"-20 Lock nut

